

RoHS Compliant Product
A suffix of "-C" specifies halogen free

DESCRIPTION

The SSG06N15V-C is the highest performance trench N-Ch MOSFETs with extreme high cell density, which provide excellent $R_{DS(ON)}$ and gate charge for most of the synchronous buck converter applications.

The SSG06N15V-C meet the RoHS and Green Product requirement with full function reliability approved.

FEATURES

- High Speed Power Switching
- Super Low Gate Charge
- Green Device Available

MARKING

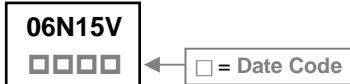

PACKAGE INFORMATION

Package	MPQ	Leader Size
SOP-8	2.5K	13 inch

ORDER INFORMATION

Part Number	Type
SSG06N15V-C	Lead (Pb)-free and Halogen-free

ABSOLUTE MAXIMUM RATINGS ($T_A=25^\circ\text{C}$ unless otherwise specified)

Parameter	Symbol	Ratings	Unit
Drain-Source Voltage	V_{DS}	150	V
Gate-Source Voltage	V_{GS}	± 20	V
Continuous Drain Current ¹ @ $V_{GS}=10\text{V}$	I_D	$T_A=25^\circ\text{C}$	6
		$T_A=70^\circ\text{C}$	4.8
Pulsed Drain Current ²	I_{DM}	28	A
Total Power Dissipation ³	P_D	3.1	W
Operating Junction & Storage Temperature Range	T_J, T_{STG}	-55~150	$^\circ\text{C}$
Thermal Resistance Ratings			
Thermal Resistance Junction-Ambient ¹	$R_{\theta JA}$	$t \leq 10\text{s}, 40$	$^\circ\text{C/W}$
		Steady State, 75	
Thermal Resistance Junction-Case ¹	$R_{\theta JC}$	24	

SOP-8

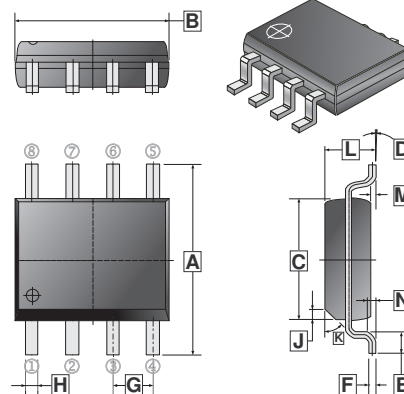

REF.	Millimeter		REF.	Millimeter	
	Min.	Max.		Min.	Max.
A	5.79	6.20	H	0.33	0.51
B	4.70	5.11	J	0.375 REF.	
C	3.80	4.00	K	45° REF.	
D	0°	8°	L	1.3	1.752
E	0.40	1.27	M	0	0.25
F	0.10	0.25	N	0.25 REF.	
G	1.27 TYP.				

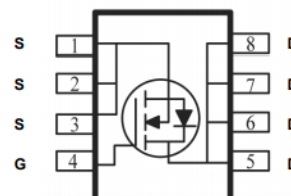

ELECTRICAL CHARACTERISTICS (T_J=25°C unless otherwise specified)

Parameter	Symbol	Min.	Typ.	Max.	Unit	Test Conditions	
Drain-Source Breakdown Voltage	B _{VDS}	150	-	-	V	V _{GS} =0, I _D =250μA	
Gate Threshold Voltage	V _{GS(th)}	2	-	4	V	V _{DS} =V _{GS} , I _D =250μA	
Forward Transfer Conductance	g _{fs}	-	25	-	S	V _{DS} =5V, I _D =6A	
Gate-Source Leakage Current	I _{GSS}	-	-	±100	nA	V _{GS} = ±20V	
Drain-Source Leakage Current	T _J =25°C	I _{DSS}	-	-	1	μA	V _{DS} =120V, V _{GS} =0
	T _J =55°C		-	-	5		V _{DS} =120V, V _{GS} =0
Static Drain-Source On-Resistance ²	R _{DS(ON)}	-	47	58	mΩ	V _{GS} =10V, I _D =6A	
Total Gate Charge	Q _g	-	23	-	nC	I _D =6A V _{DS} =75V V _{GS} =10V	
Gate-Source Charge	Q _{gs}	-	5.8	-			
Gate-Drain Charge	Q _{gd}	-	4.2	-			
Turn-on Delay Time	T _{d(on)}	-	16.2	-	nS	V _{DD} =75V I _D =6A V _{GS} =10V R _G =3.3Ω	
Rise Time	T _r	-	18.6	-			
Turn-off Delay Time	T _{d(off)}	-	28.5	-			
Fall Time	T _f	-	6.5	-			
Input Capacitance	C _{iss}	-	1190	-	pF	V _{GS} =0 V _{DS} =75V f=1MHz	
Output Capacitance	C _{oss}	-	73	-			
Reverse Transfer Capacitance	C _{rss}	-	4	-			
Source-Drain Diode							
Continuous Source Current ¹	I _S	-	-	6	A	V _G =V _D =0, Force Current	
Diode Forward Voltage ²	V _{SD}	-	-	1.2	V	V _{GS} =0, I _S =1A	
Reverse Recovery Time	T _{rr}	-	45	-	nS	I _F =6A, dI/dt=100A/μs	
Reverse Recovery Charge	Q _{rr}	-	138	-	nC	T _J =25°C	

Notes:

- The data tested by surface mounted on 1inch² FR4 Board with 2OZ copper.
- The data tested by pulsed, Pulse Width≤300μs, Duty Cycle≤2%.
- The power dissipation is limited by 150°C, junct ion temperature.

TYPICAL CHARACTERISTICS CURVE

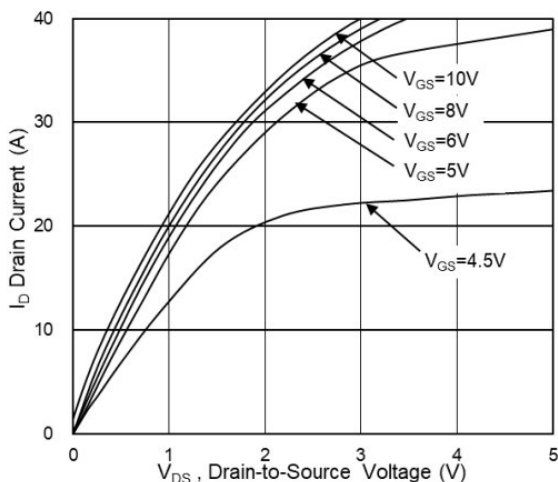

Fig.1 Typical Output Characteristics

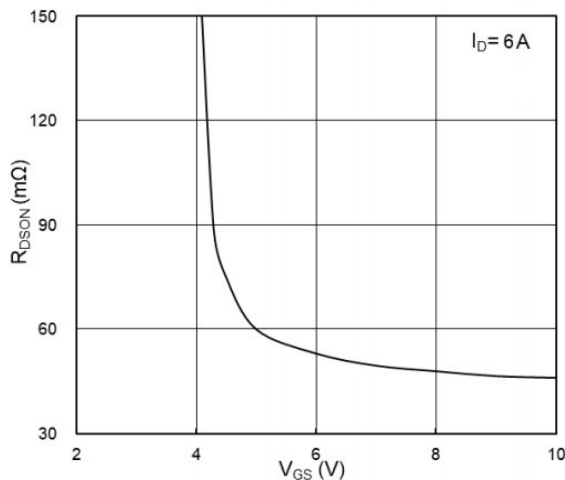

Fig.2 On-Resistance vs G-S Voltage

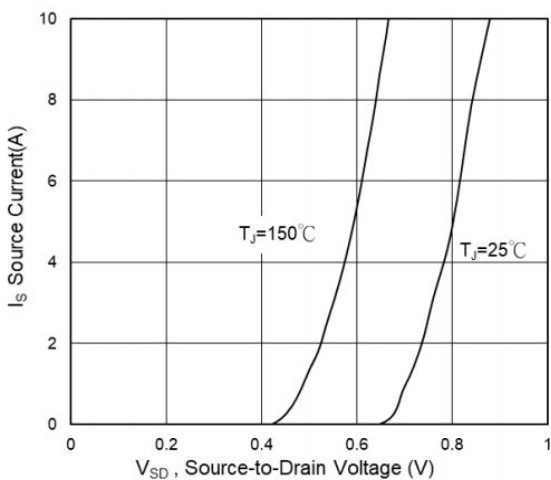

Fig.3 Source Drain Forward Characteristics

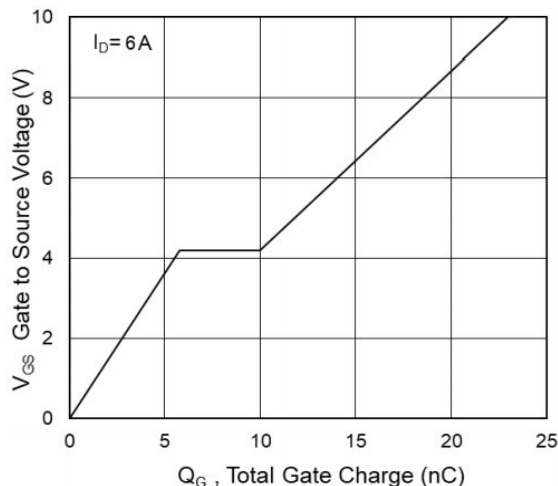

Fig.4 Gate-Charge Characteristics

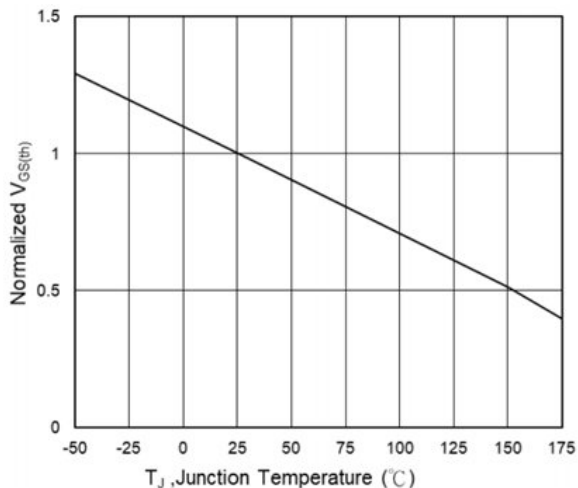

Fig.5 Normalized $V_{GS(th)}$ vs T_J

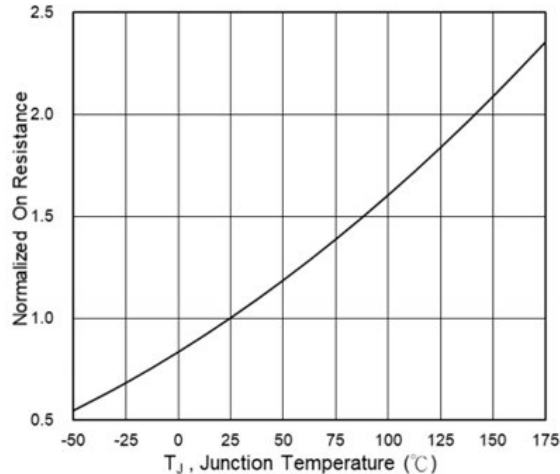

Fig.6 Normalized $R_{DS(on)}$ vs T_J

TYPICAL CHARACTERISTICS CURVE

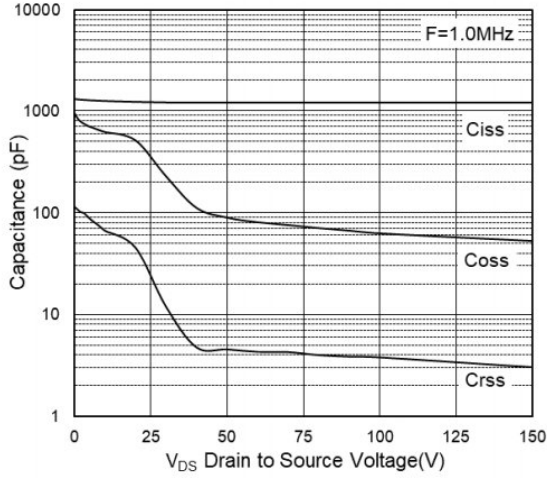

Fig.7 Capacitance

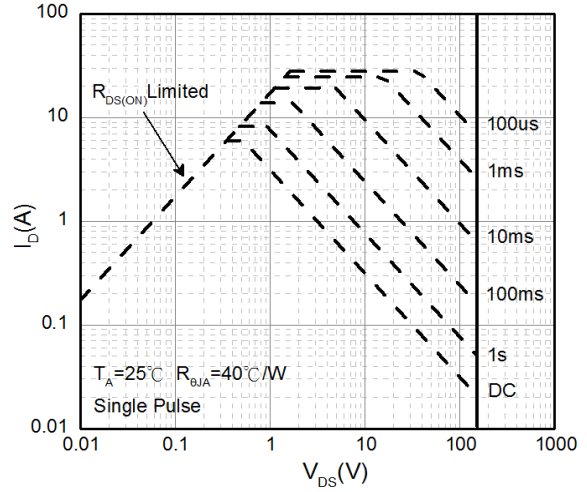

Fig.8 Safe Operating Area

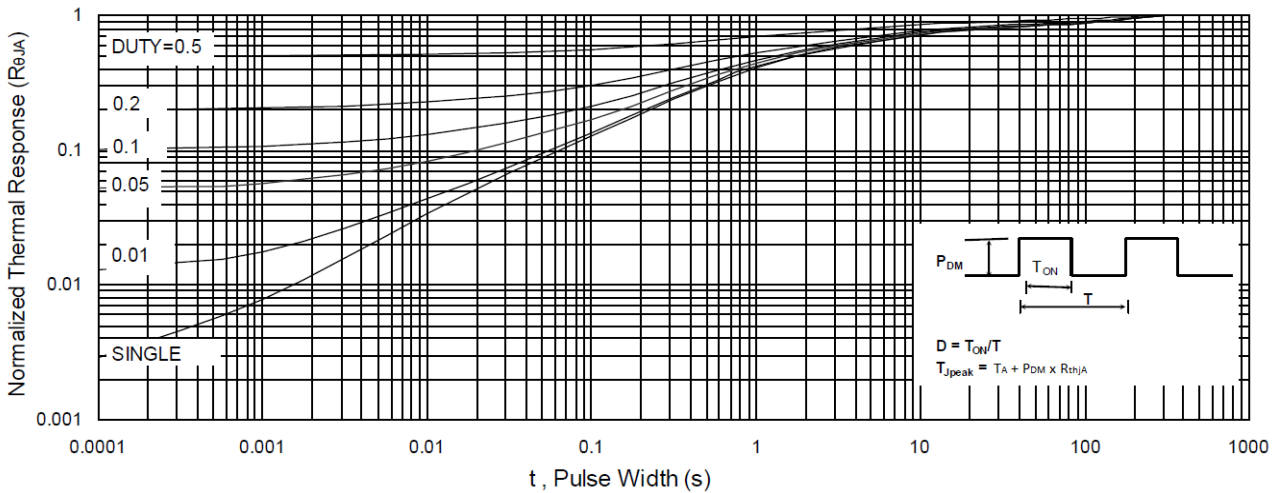

Fig.9 Normalized Maximum Transient Thermal Impedance

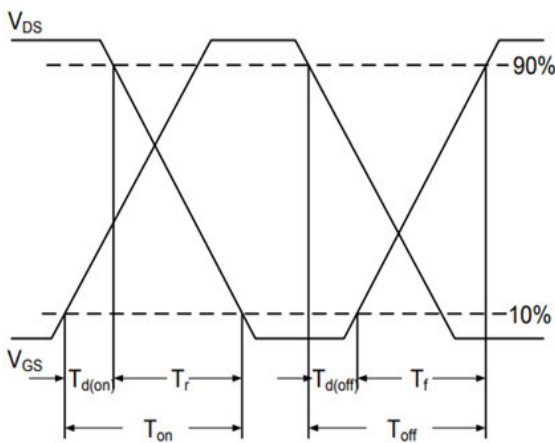

Fig.10 Switching Time Waveform

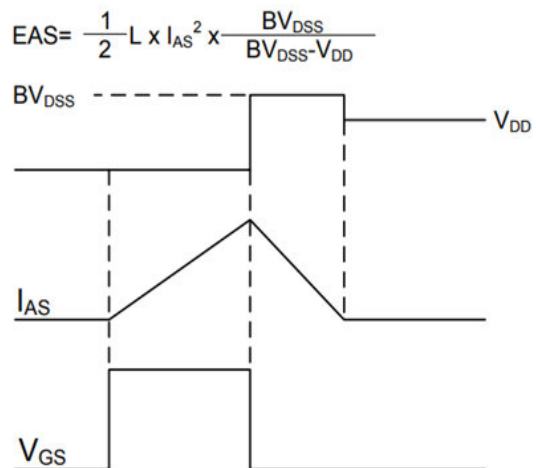

Fig.11 Unclamped Inductive Switching Waveform