

RoHS Compliant Product

A suffix of "-C" specifies halogen & lead-free

FEATURES

- Fast Switching Speed
- Surface Mount Package Ideally Suited for Automatic Insertion
- For General Purpose Switching Applications
- High Conductance

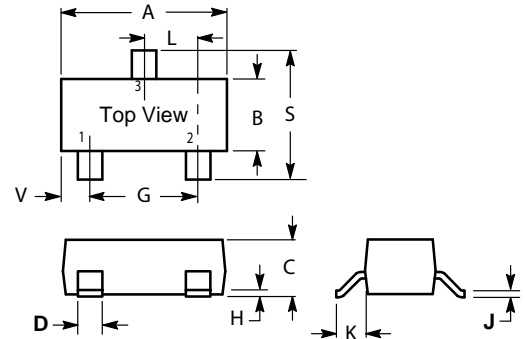
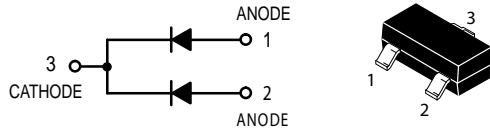

MAXIMUM RATINGS (EACH DIODE)

Rating	Symbol	Value	Unit
Reverse Voltage	V_R	50	Vdc
Forward Current	I_F	200	mAdc
Peak Forward Surge Current, $T=1s$	$I_{FM}(\text{surge})$	0.5	Adc
$T=1ms$		1	
$T=1\mu s$		4	

SOT-23		
Dim	Min	Max
A	2.800	3.040
B	1.200	1.400
C	0.890	1.110
D	0.370	0.500
G	1.780	2.040
H	0.013	0.100
J	0.085	0.177
K	0.450	0.600
L	0.890	1.020
S	2.100	2.500
V	0.450	0.600
All Dimension in mm		

THERMAL CHARACTERISTICS

Characteristic	Symbol	Max	Unit
Total Device Dissipation FR-5 Board ⁽¹⁾ $T_A = 25^\circ C$ Derate above $25^\circ C$	P_D	225	mW
		1.8	mW/ $^\circ C$
Thermal Resistance, Junction to Ambient	$R_{\theta JA}$	556	$^\circ C/W$
Total Device Dissipation Alumina Substrate, ⁽²⁾ $T_A = 25^\circ C$ Derate above $25^\circ C$	P_D	300	mW
		2.4	mW/ $^\circ C$
Thermal Resistance, Junction to Ambient	$R_{\theta JA}$	417	$^\circ C/W$
Junction and Storage Temperature	T_J, T_{stg}	-55 to +150	$^\circ C$

DEVICE MARKING

BAV74 = JA

ELECTRICAL CHARACTERISTICS ($T_A = 25^\circ C$ unless otherwise noted) (EACH DIODE)

Characteristic	Symbol	Min	Max	Unit
----------------	--------	-----	-----	------

OFF CHARACTERISTICS

Reverse Breakdown Voltage ($I_{BR} = 5 \mu A_{dc}$)	$V_{(BR)}$	50	—	Vdc
Reverse Voltage Leakage Current ($V_R = 50 V_{dc}, T_J = 125^\circ C$) ($V_R = 50 V_{dc}$)	I_R	—	100 0.1	μA_{dc}
Diode Capacitance ($V_R = 0, f = 1.0 MHz$)	C_D	—	2.0	pF
Forward Voltage ($I_F = 100 mA_{dc}$)	V_F	—	1	Vdc
Reverse Recovery Time ($I_F = I_R = 10 mA_{dc}, I_{R(REC)} = 1.0 mA_{dc}$) (Figure 1) $R_L = 100 \Omega$	t_{rr}	—	4.0	ns

1. FR-5 = 1.0 X 0.75 X 0.062 in. 2. Alumina = 0.4 X 0.3 X 0.024 in. 99.5% alumina.

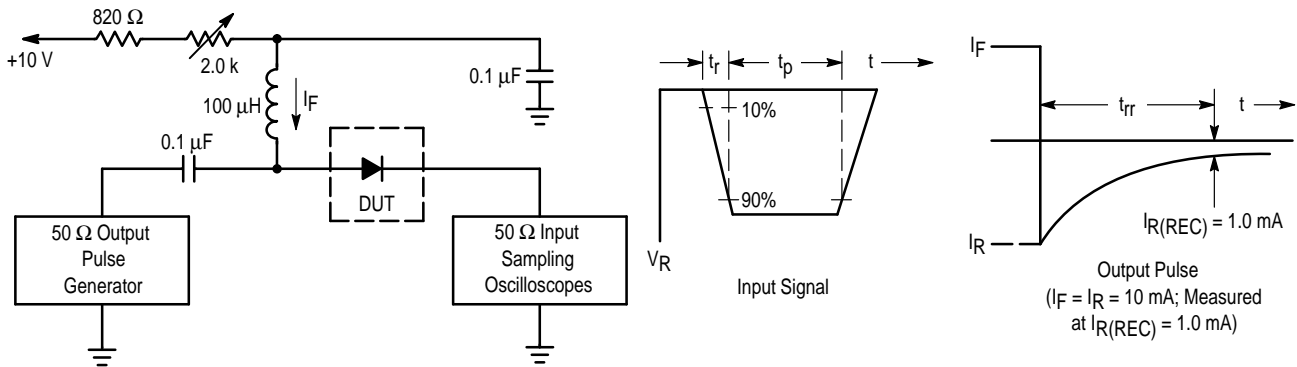

- Notes: 1. A 2.0 kΩ variable resistor adjusted for a Forward Current (I_F) of 10 mA.
2. Input pulse is adjusted so $I_{R(peak)}$ is equal to 10 mA.
3. $t_p \gg t_{rr}$

Figure 1. Recovery Time Equivalent Test Circuit

Curves Applicable to Each Anode

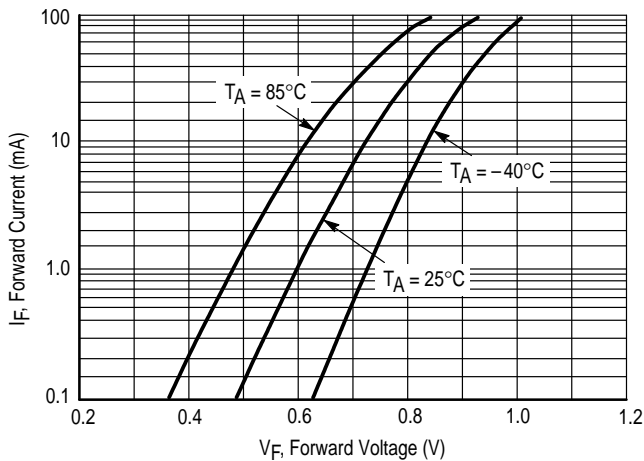

Figure 2. Forward Voltage

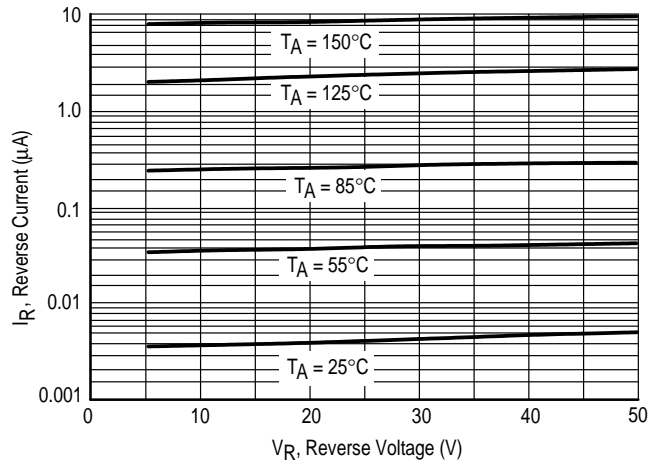

Figure 3. Leakage Current

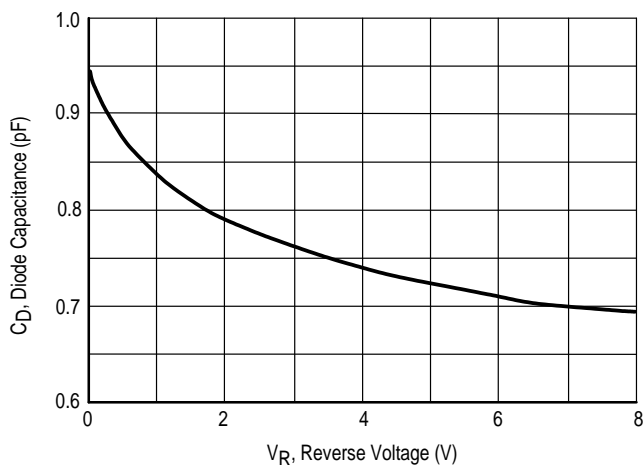

Figure 4. Capacitance

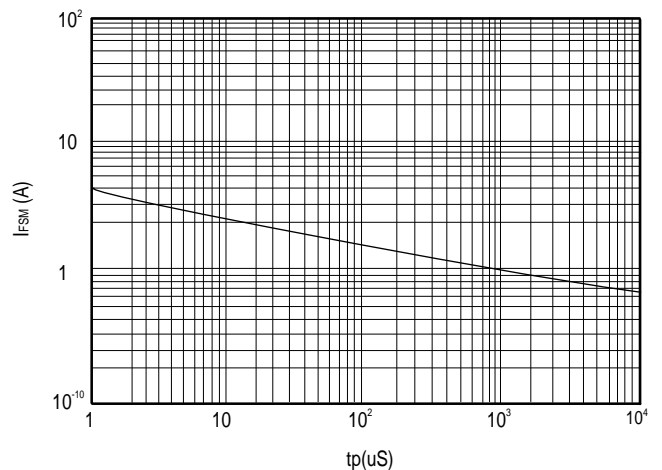

Figure 5. Forward Surge